



Performance Under Pressure

OPERATOR'S MANUAL FOR MODELS
CD-1002-0MUH/UC &
CD-1502-0MUH/UC
COLD WATER ELECTRICAL
PRESSURE WASHERS



**CAUTION
RISK OF INJURY!**

READ MANUAL BEFORE OPERATING!

This manual is an important part of the pressure washer and must remain with the unit when you sell or rent it!

TABLE OF CONTENTS

INTRODUCTION	3
IMPORTANT SAFETY WARNINGS	4-7
ELECTRICAL PRECAUTIONS	4
SPRAY PRECAUTIONS	5
DETERGENT CLEANING PRECAUTIONS.....	6
MISCELLANEOUS SAFETY PRECAUTIONS.....	6
ADJUSTMENT PRECAUTIONS	7
FEATURES	8
SAFETY DECALS	9
INSTALLATION & PREPARATION	10-13
ATTIRE.....	10
SET-UP	10
NOZZLE REVIEW.....	10
NOZZLE CONNECTION.....	11
WATER SUPPLY.....	11
UNLOADER	12
POWER CORD CONNECTION.....	12
PRE-START INSPECTION PROCEDURES.....	12
OPERATING INSTRUCTIONS	14-15
PRIMING THE PUMP	14
START-UP.....	14
CLEANING WITH DETERGENTS	15
SHUTDOWN.....	15
STORAGE & MAINTENANCE	16-17
SPECIFIC MAINTENANCE	16
WINTERIZING	16-17
START UP AFTER EXTENDED STORAGE	17
TROUBLESHOOTING	18-19
ACCESSORIES	19
STATEMENT OF WARRANTY	20
NOTES	21

WARNING

This product contains one or more chemicals known to the State of California to cause cancer and birth defects or other reproductive harm.

INTRODUCTION

Congratulations on the purchase of your Mi-T-M® pressure washer! You can be assured your Mi-T-M® pressure washer was constructed and designed with quality and performance in mind. Each component has been rigorously tested to ensure the highest level of acceptance.

This operator's manual was compiled for your benefit. By reading and following the simple safety, installation, operation, maintenance and troubleshooting steps described in this manual, you will receive years of trouble free operation from your Mi-T-M® pressure washer. The contents of this manual are based on the latest product information available at the time of publication. Mi-T-M® reserves the right to make changes in price, color, materials, equipment, specifications or models at any time without notice.

! IMPORTANT !

These paragraphs are surrounded by a "SAFETY ALERT BOX". This box is used to designate and emphasize Safety Warnings that must be followed when operating this pressure washer. Accompanying the Safety Warnings are "signal words" which designate the degree or level of hazard seriousness. The "signal words" used in this manual are as follows:

DANGER: Indicates an imminently hazardous situation which, if not avoided, WILL result in death or serious injury.

WARNING: Indicates a potentially hazardous situation which, if not avoided, COULD result in death or serious injury.

CAUTION: Indicates a potentially hazardous situation which, if not avoided MAY result in minor or moderate injury.



The symbols set to the left of this paragraph are "Safety Alert Symbols". These symbols are used to call attention to items or procedures that could be dangerous to you or other persons using this equipment.



ALWAYS PROVIDE A COPY OF THIS MANUAL TO ANYONE USING THIS EQUIPMENT. READ ALL INSTRUCTIONS BEFORE OPERATING THIS PRESSURE WASHER AND ESPECIALLY POINT OUT THE "SAFETY WARNINGS" TO PREVENT THE POSSIBILITY OF PERSONAL INJURY TO THE OPERATOR.



Once the unit has been uncrated, immediately write in the serial number of your unit in the space provided below.

SERIAL NUMBER _____

Inspect for signs of obvious or concealed freight damage. If damage does exist, file a claim with the transportation company immediately. Be sure that all damaged parts are replaced and that the mechanical problems are corrected prior to operation of the unit. If you require service, contact Customer Service at 800-228-6172

Please have the following information available for all service calls:

1. Model Number
2. Serial Number
3. Date and Place of Purchase

Mi-T-M Corporation
8650 Enterprise Drive
Peosta, IA 52068

IMPORTANT SAFETY INSTRUCTIONS



WARNING: When using this product, basic precautions should always be observed, including the following:
READ ALL SAFETY INSTRUCTIONS BEFORE USING PRESSURE WASHER



ELECTRICAL PRECAUTIONS:

1. **GROUNDING INSTRUCTIONS:** This product must be grounded. If it should malfunction or breakdown, grounding provides a path of least resistance for electric current to reduce the risk of electric shock. This product is equipped with a cord having an equipment-grounding conductor and a grounding plug. The plug must be plugged into an appropriate outlet that is properly installed and grounded in accordance with all local codes and ordinances.
2. **DANGER:** Improper connection of the equipment-grounding conductor can result in a risk of electrocution. Check with a qualified electrician or service personnel if you are in doubt as to whether the outlet is properly grounded. Do not modify the plug provided with the product - if it will not fit the outlet, have a proper outlet installed by a qualified electrician. Do not use any type of adaptor with this product.
3. **GROUND FAULT INTERRUPTER PROTECTION:** This pressure washer provided with a Ground Fault Circuit Interrupter (GFCI) built into the plug or the power supply cord. This device provides additional protection from the risk of electric shock. Should replacement of the cord become necessary, use only identical replacement parts that include GFCI protection.
4. **EXTENSION CORDS:**

WARNING
**Mi-T-M DOES NOT RECOMMEND
THE USE OF EXTENSION CORDS!**

If use of an extension cord is unavoidable, it must be plugged into a GFCI found in circuit boxes or protected receptacles. When using an extension cord, observe the following:

<u>Cable Length</u>	<u>Wire Gauge/1002</u>	<u>Wire Gauge/1502</u>
Up to 50 feet	14 AWG	12 AWG
50 to 100 feet	12 AWG	10 AWG

Use only 3-wire extension cords that have 3-prong grounding-type plugs and 3-pole cord connectors that accept the plug from the product. Use only extension cords that are intended for outdoor use. These extension cords are identified by a marking "Acceptable for use with outdoor appliances; store indoors while not in use." Use only extension cords having an electrical rating not less than the rating of the product. Do not use damaged extension cords. Examine extension cord before using and replace if damaged. Do not abuse extension cord and do not yank on any cord to disconnect. Keep cord away from heat and sharp edges. Always disconnect the extension cord from the receptacle before disconnecting the product from the extension cord.

WARNING

To reduce the risk of electrocution, keep all connections dry and off the ground. Do not allow electrical cords to lay in water or in such a position where water could come in contact with them. Do not touch plug with wet hands

5. DO NOT drop the GFCI as damage could result. If the GFCI is accidentally dropped, be certain to test the GFCI before using to ensure it is working properly. (Follow instructions on GFCI for test procedures.)
6. DO NOT pull on the electrical cord to disconnect from the outlet, OR carry the unit by the cord.
7. Check power cord for damage before using. There is a hazard of electrical shock from crushing, cutting or heat damage.
8. Always be certain the unit is receiving proper voltage. Before plugging the unit into a compatible power source, be certain the switch is in the "OFF" position. Disconnect when not in use.
9. DO NOT use the unit in an area where flammable gas vapors may be present. An electric spark could cause an explosion or fire.
10. DO NOT direct water spray on or into electrical installations of any kind. This includes electrical outlets, light bulbs, fuse boxes, transformers, the unit itself, etc. Severe electrical shock may occur.
11. Mi-T-M does not recommend the owner attempt any electrical repairs to this unit.

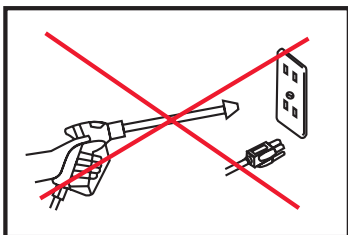
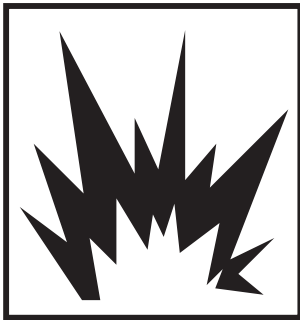

IMPORTANT SAFETY INSTRUCTIONS
READ ALL SAFETY INSTRUCTIONS BEFORE USING PRESSURE WASHER



SPRAY PRECAUTIONS:



DANGER

RISK OF INJECTION OR SEVERE CUTTING INJURY

KEEP CLEAR OF NOZZLE

DO NOT DIRECT DISCHARGE STREAM AT PERSONS OR PETS WHEN USING THIS PRODUCT, BASIC PRECAUTIONS SHOULD ALWAYS BE OBSERVED, INCLUDING THE FOLLOWING:

1. KEEP AWAY FROM THE SPRAY:
 - a. Because of the high pressure and velocity of the spray, fluids can penetrate the skin, causing serious injury.
 - b. Never point the gun at yourself or anyone else. Never put your hand, fingers or body directly over the spray nozzle. Always keep operating area clear of all persons. Use **extreme** caution when operating near children.
 - c. If an accident does occur and the spray appears to have penetrated the skin, **SEEK EMERGENCY MEDICAL CARE. DO NOT TREAT AS A SIMPLE CUT.** If you are using cleaning agents, be prepared to tell a physician exactly what kind.
2. ALWAYS wear protective goggles when operating the unit to shield the eyes from flying debris and detergents. Other protective equipment such as rubber suits, gloves and respirators are advisable, especially when using cleaning detergents. Use **extreme** caution when operating near children.
3. Stay alert-watch what you are doing. Do not operate the unit when fatigued or under the influence of alcohol or drugs.
4. NEVER squeeze the trigger unless securely braced. The thrust from the water traveling through the nozzle may be powerful enough to cause the operator to lose balance if unprepared. DO NOT overreach or stand on unstable support. Wet surfaces can be slippery, wear protective foot gear and keep good footing and balance at all times. NEVER trigger the gun while on a ladder or roof.
5. Caution should be used when directing spray toward fragile materials such as glass. Shattering could result in serious injury.
6. ALWAYS hold on firmly to the gun/wand assembly when starting and operating the unit. Failure to do so can cause the wand to fall and whip dangerously. NEVER operate the gun with the trigger wired in the open position. To prevent accidental discharge, the trigger gun should be securely locked when not in use.
7. Even after you shut off the unit, there is high pressure water left in the pump, hose and gun until you release it by triggering the gun. Before removing the spray nozzle or servicing the unit, ALWAYS shut off the unit and trigger the gun to release trapped pressure.

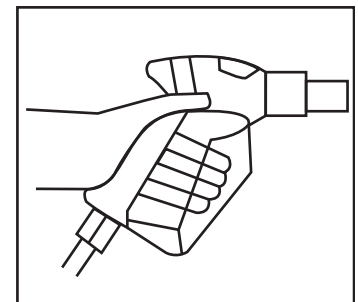
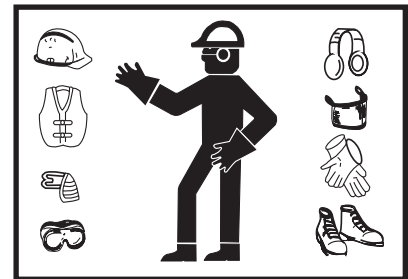

IMPORTANT SAFETY INSTRUCTIONS
READ ALL SAFETY INSTRUCTIONS BEFORE USING PRESSURE WASHER



DETERGENT CLEANING PRECAUTIONS:

1. DO NOT use solvents or highly corrosive detergents or acid type cleaners with this pressure washer. Use only mild detergents.
2. KNOW YOUR DETERGENTS! Be prepared to tell a physician exactly what you are using in the event of an emergency. Read the Material Safety Data Sheet (MSDS) provided with your detergent and all detergent labels. Follow all appropriate instructions regarding preparation use, safety and transportation. Keep ALL detergents out of the reach of children.
3. DO NOT use this pressure washer to dispense hazardous detergents.
4. DO NOT alter the detergent injection feature in any manner not prescribed in this manual. Use only genuine Mi-T-M replacement parts for necessary repairs.



MISCELLANEOUS SAFETY PRECAUTIONS:

1. NEVER ALLOW CHILDREN OR ADOLESCENTS TO OPERATE THIS UNIT!
2. Read and follow all handling, operations, maintenance and safety instructions listed in this manual and provide such information to ANYONE who will be operating this unit.
3. This pressure washer is provided with a Ground Fault Circuit Interrupter (GFCI) built into the plug or the power supply cord. Should replacement of the cord or plug become necessary, use only identical replacement parts that include GFCI protection.
4. In freezing temperatures, the unit must always be warm enough to ensure there is no ice formation in the pump. DO NOT start this unit if it has been transported in an open or underheated vehicle without first allowing the pump to thaw.
5. When connecting the water inlet to the water supply mains, local regulations of your water company must be observed. In some areas the unit must not be connected directly to the public drinking water supply. This is to ensure that there is no feedback of the detergents into the water supply. (Direct connection is permitted if a back flow preventer is installed.)
6. High pressure hoses should be inspected daily for signs of wear. If evidence of failure exists, promptly replace all suspect hoses to prevent the possibility of injury from the high pressure spray. If a hose or fitting is leaking, NEVER place your hand directly on the leak.
7. DO NOT operate the unit if you see any pump oil or water leaks from the machine. DO NOT resume operation until the unit has been inspected and repaired by a qualified service person.
8. DO NOT operate the unit without all protective covers in place.
9. To reduce the risk of injury, maintain a safe distance from persons while operating this unit. Close supervision is necessary when operating the unit near children.
10. DO NOT leave pressurized unit unattended. Shut off the unit and release trapped pressure before leaving.
11. DO NOT move the unit by pulling on the hose.

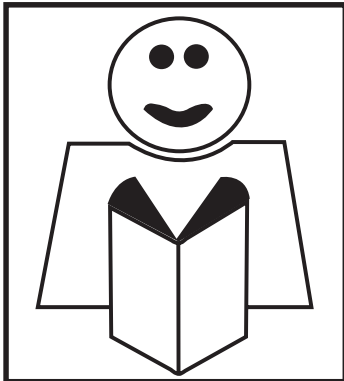

IMPORTANT SAFETY INSTRUCTIONS
READ ALL SAFETY INSTRUCTIONS BEFORE USING PRESSURE WASHER



ADJUSTMENT PRECAUTIONS:

1. NEVER alter or modify the equipment, be sure any accessory items and system components being used will withstand the pressure developed. Use ONLY genuine Mi-T-M parts for repair of your pressure washer. Failure to do so can cause hazardous operating conditions and will void warranty.
2. NEVER make adjustments to the machinery while it is connected to the power source.
3. Know how to stop the pressure washer and bleed pressures quickly. Be thoroughly familiar with controls.
4. Before servicing the unit; turn the unit off, disconnect from the power source, relieve the water pressure, and allow the unit to cool down. Service in a clean, dry, flat area.
5. Follow the maintenance instructions specified in this manual.



! SAVE THESE INSTRUCTIONS !



FEATURES

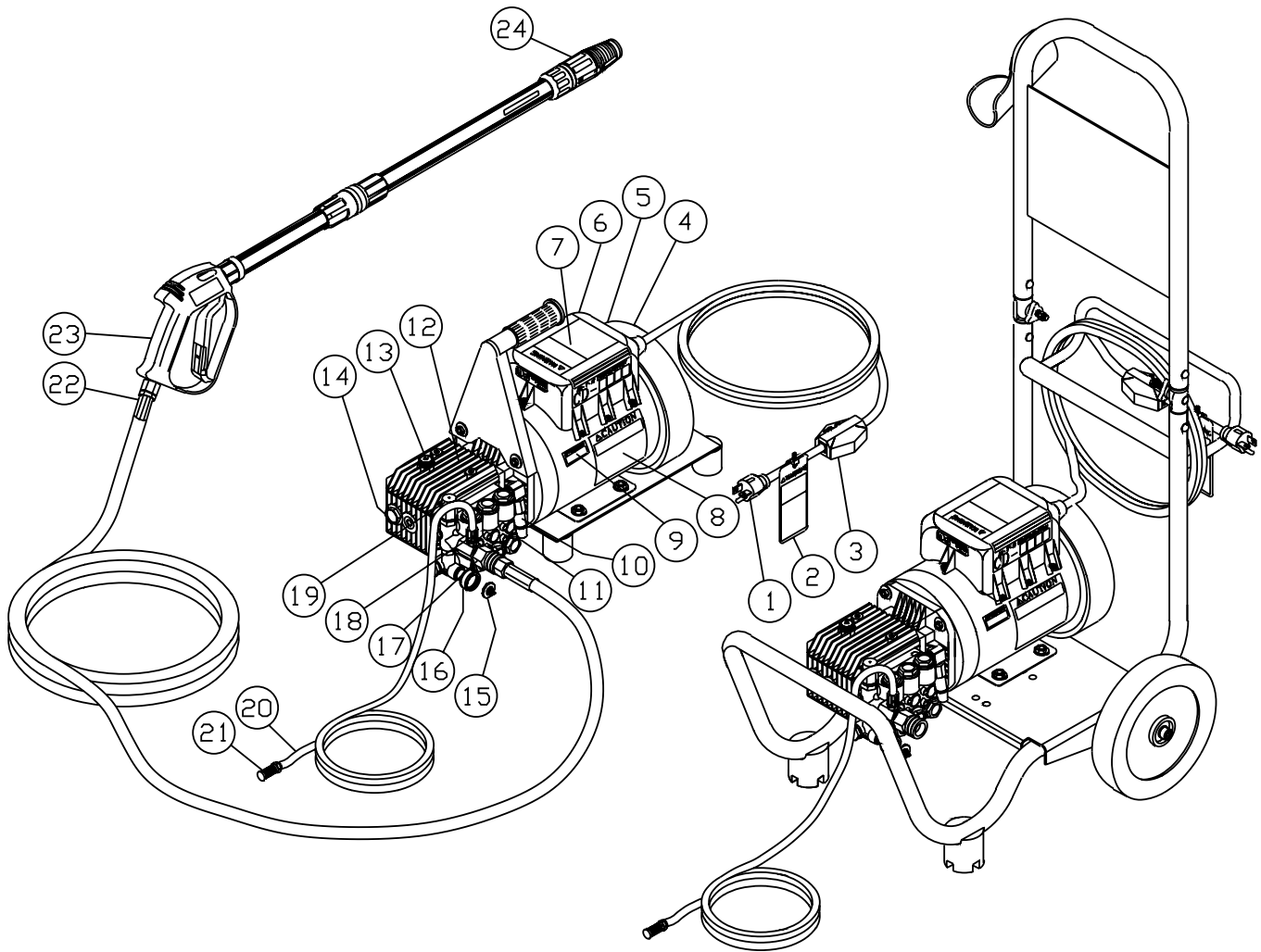

CD-ELEC-0 FEATURES-090799-RD

FEATURES LISTING

- | | |
|--|----------------------------------|
| 1. Power Cord | 13. Oil Dipstick |
| 2. Decal: Warning-Risk of Electrocutation | 14. Oil Sight Glass |
| 3. GFCI | 15. Water Inlet Strainer |
| 4. Motor | 16. Water Inlet |
| 5. On/Off Switch | 17. Water Outlet |
| 6. Decal: Warning-Risk of Injection/Explosion | 18. Adjustable Detergent Knob |
| 7. Decal: Warning-Risk of Electrocutation | 19. Adjustable Unloader Knob |
| 8. Decal: Caution Statements | 20. Detergent Hose |
| 9. Decal: Warning-Backflow Preventer/Bilingual | 21. Detergent Strainer |
| 10. Pressure Relief Valve | 22. High Pressure Discharge Hose |
| 11. Heat Dump Valve | 23. Gun |
| 12. Pump | 24. Variable Nozzle Assembly |

SAFETY DECALS & PLACEMENT
DO NOT REMOVE SAFETY DECALS FROM UNIT UNLESS
REPLACING WITH MOST CURRENT SAFETY DECAL!!

Reference #7 Decal: Warning-Risk of Electrocutation
 (Part #34-0916)



Reference #2 Tag: Risk of Electrocutation
 (Part #34-0628)



Reference #8 Decal: Caution Statements (Part #34-0632)

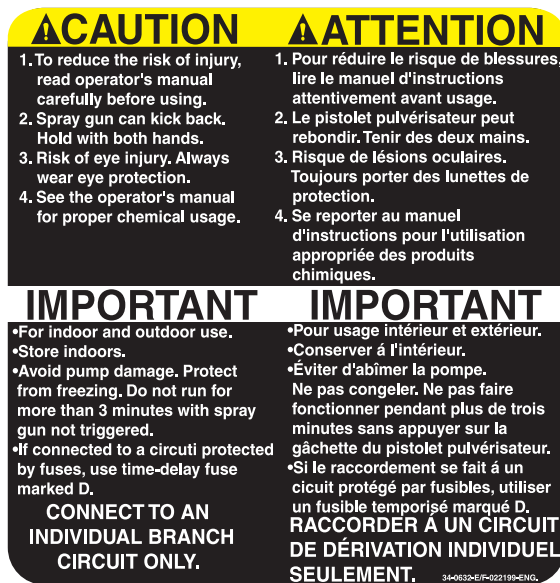

Reference #9 Decal: Warning-Backflow Preventer
 (Part #34-0469)



Reference #6 Decal: Warning-Risk of Injection/Explosion
 (Part #34-0631)

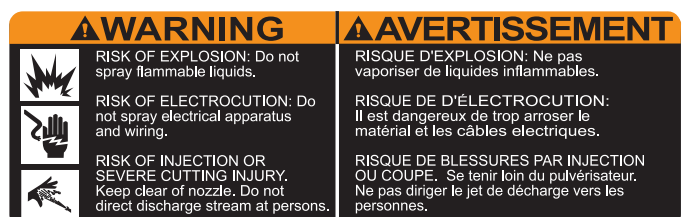



INSTALLATION & PREPARATION

ATTIRE:

Proper attire is essential to your safety. It is advised to utilize whatever means necessary to protect eyes, ears, and skin. Additional safety attire (such as respiratory mask) may be required when using detergent cleaning agents with this washer.

SET-UP:

1. This unit should only be placed on a level surface to ensure proper lubrication for the water pump while operating. NEVER spray water directly on the unit!
2. Do not place unit in an area:
 - a. where there is evidence of oil or gas leaks.
 - b. where flammable gas vapors may be present.
3. Do not allow the unit to be exposed to rain, snow or freezing temperatures. If any part of the unit becomes frozen; excessive pressure may build up in the unit which could cause it to burst, resulting in possible serious injury to the operator or bystanders.
4. Before initial use, replace the oil travel plug with the dipstick provided with the unit. Be certain the oil level is in the center of the sight glass before each use. If low, fill with Mi-T-M pump oil (#AW-4085-0016). DO NOT OVERFILL!



WARNING

RISK OF EXPLOSION!

DO NOT OPERATE UNIT IN AN AREA WHERE FLAMMABLE GAS VAPORS MAY BE PRESENT. AN ELECTRIC SPARK MAY CAUSE AN EXPLOSION.

RISK OF BURSTING!

DO NOT STORE / OPERATE UNIT IN A FREEZING ENVIRONMENT.



WARNING

RISK OF INJECTION CAUSING SEVERE INJURY!

-NEVER LOOK DIRECTLY AT THE NOZZLE ORIFICE UNLESS IT IS DISCONNECTED FROM THE GUN/WAND ASSEMBLY!

-WHEN USING THE ADJUSTABLE NOZZLE, NEVER ADJUST THE SPRAY PATTERN WHILE THE TRIGGER GUN IS OPEN!

NOZZLE REVIEW:

The Adjustable Spray Pattern Nozzle (with lance) has two functions:

NOTE: Nozzle assembly should NOT be connected to the gun assembly at this time.

1. Selections of high and low pressure can be achieved by pulling the nozzle cover at the end of the wand "TOWARD" yourself for the High Pressure setting, and pushing the nozzle cover "AWAY" from yourself for Low Pressure and detergent application.
2. The spray pattern can be adjusted from 0° to 65° by rotating the nozzle cover at the end of the wand in a clockwise and counter-clockwise direction. Be cautious when using the straight narrow stream. It is not recommended for use on painted or wood surfaces OR items attached with adhesive backings.

ADJUSTABLE NOZZLE

LOW PRESSURE/DETERGENT

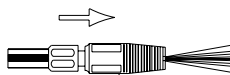

NOZZLE COVER

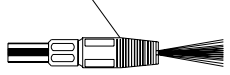

HIGH PRESSURE

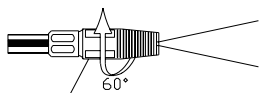

NOZZLE COVER

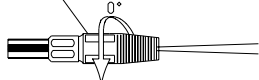

INSTALLATION & PREPARATION

NOZZLE CONNECTION:

1. Be certain the trigger gun is locked in the "OFF" position. See *WARNING*, right.
2. The nozzle assembly should be disconnected from the gun assembly at this time by unscrewing the nozzle/lance assembly from the gun/lance assembly.

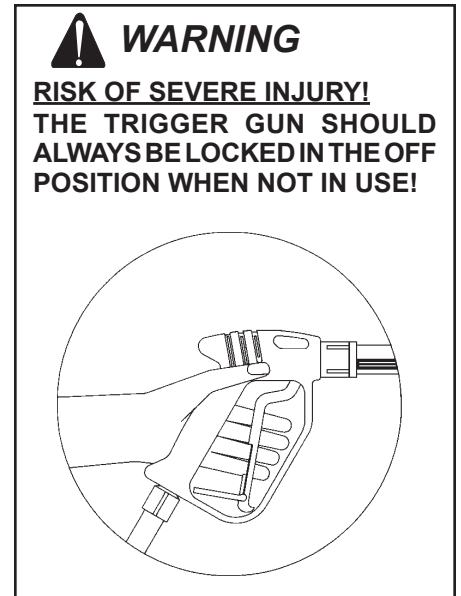
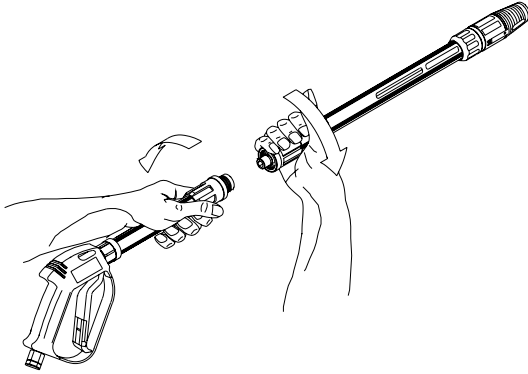

WATER SUPPLY:

1. Select a water supply hose which is a quality grade of garden hose measuring at least 3/4" ID and no longer than 50 feet.
2. Check the water inlet strainer to ensure it is clean and free of any obstructions. Periodic cleaning of the water strainer will help prevent pump problems. As a strainer becomes obstructed, it restricts proper flow of water to the pump. This can result in cavitations which will cause premature failure of pump packings and valves. Using a screw driver, remove the screen; clean or replace with Mi-T-M #19-0001 if necessary.
3. Connect the hoses.
 - a. Connect one end of the water supply hose to the water inlet of the unit.
 - b. Connect the other end of the hose to your pressurized water supply.

NOTE: Do not use a non-pressurized water supply (i.e. from a well or pond) with this unit.

- c. Connect the high pressure discharge hose to the water outlet of the unit.
4. Follow the incoming water requirements listed below:
 - a. Water pressure must be a minimum of 25 pounds per square inch (PSI) and a maximum of 125 PSI. (A typical outdoor faucet will generally supply this PSI if turned completely "ON".)
 - b. Incoming GPM must be approximately one gallon more than the outgoing GPM stated on the pressure washer nameplate. (You can check GPM by timing how long it takes to fill a 5 gallon container.
 - c. Incoming water temperature must not exceed 125°F (52°C). Excessive pump damage may result if the water temperature exceeds this acceptable level.
 5. Never allow the unit to operate without the incoming water line attached and the water supply turned all the way on.

CHECK WATER INLET STRAINER

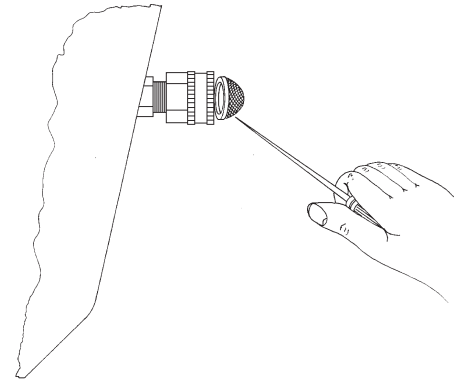

INSTALLATION & PREPARATION



CAUTION

RISK OF UNIT DAMAGE!

DO NOT OVERTIGHTEN THE UNLOADER. BREAKAGE WILL RESULT IN IMMEDIATE LOSS OF WATER PRESSURE AND COSTLY REPAIRS.

UNLOADER:

The unloader valve on your machine is equipped with an adjustment knob to adjust the pressure. Should less pressure be required, simply turn the adjustment knob counterclockwise. To set back to maximum, turn adjustment knob completely clockwise. **DO NOT OVERTIGHTEN!**



WARNING

RISK OF ELECTROCUTION!

THIS UNIT MUST BE CONNECTED TO A PROPERLY GROUNDED OUTLET. DO NOT USE AN ADAPTER OR REMOVE THE THIRD GROUNDING PRONG.

POWER CORD CONNECTION:

1. Make certain the motor switch is in the "OFF" position.
2. For 1000 PSI, ensure electrical supply is 120Volt / 15 Amp / 60 Hertz. (See Figure A, Left)
For 1500 PSI, ensure electrical supply is 120Volt / 20 Amp / 60 Hertz. (See Figure B, Left)
3. Each time the GFCI is plugged onto an outlet, test the GFCI according to the instructions on the GFCI. Do not use the unit if the test fails!
4. Ensure the area between the pressure washer cord and the outlet is kept dry.
5. Insert the male plug into a grounded AC outlet. **DO NOT use an adapter OR remove the grounding plug!!**

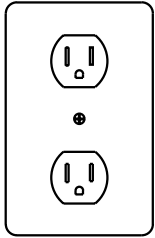

(A)

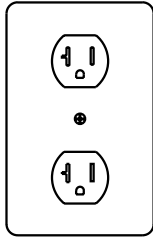

(B)

THERMAL RELIEF VALVE:

To ensure the bypass water temperature does not exceed acceptable levels, never allow the pressure washer to operate in the bypass mode (with the unit running and the trigger closed) for more than three minutes.

A thermal relief valve has been added to this unit to protect the pump. It may begin to open and release water if the water temperature in the pump has exceeded 140° F. This will allow fresh, cool water to enter the system, therefore preventing premature failure of pump packings.

INSTALLATION & PREPARATION

PRE-START INSPECTION PROCEDURES:

Before starting the unit, perform the following procedures:

1. Check the oil level in the pump.
 2. Inspect the inlet water strainer. Clean or replace if necessary. See "Water Supply", #2, pg. 11.
 3. Check all hose connections to ensure they are securely tightened. See "Water Supply", #3, pg. 11.
 4. Inspect for system water leaks and oil leaks. Be sure that all damaged parts are replaced and that the mechanical problems are corrected prior to operation of the unit. If service is needed, contact Customer Service.
 5. Inspect high pressure hose for kinking, cuts or leaks. If a cut or leak is found, DO NOT USE HOSE! Replace hose before starting unit. See "Miscellaneous Safety Precautions" #6, pg. 6. Be sure that all damaged parts are replaced and that the mechanical problems are corrected prior to operation of the unit. If you need service, contact Customer Service.
 6. Inspect electrical cord for cuts. If a cut is found, DO NOT TOUCH OR USE ELECTRICAL CORD! Replace cord before starting the unit.
-



THE FOLLOWING PAGES CONTAIN OPERATING AND MAINTENANCE INSTRUCTIONS.

DO NOT ATTEMPT TO OPERATE THIS PRESSURE WASHER UNTIL YOU HAVE READ AND UNDERSTOOD ALL SAFETY PRECAUTIONS AND INSTRUCTIONS LISTED IN THIS MANUAL.

INCORRECT OPERATION OF THIS UNIT CAN CAUSE SERIOUS INJURY!!

DO NOT ALTER OR MODIFY THIS EQUIPMENT IN ANY MANNER!

OPERATING INSTRUCTIONS

PRIMING THE PUMP:

1. It is essential to prime the pump on initial start-up and each time the water supply is disconnected from the unit after initial use.
2. Lay the high pressure hose out to remove any loops. Water flow will constrict the hose, creating tight loops if the hose is not straight.
3. Securely connect the gun assembly to the high pressure hose.

NOTE: *The nozzle assembly should NOT be connected to the gun assembly at this time. See "Nozzle Connection" pg. 11.*

4. With the trigger gun locked in the "OFF" position, turn the water supply completely on. Pointing the gun in a safe direction, unlock the trigger gun and squeeze the trigger.
5. Low pressure water will begin flowing from the hose/gun assembly. This allows the unit to prime and purge any air from the system. The unit is primed when water flow is uninterrupted by air.
6. Once the unit is primed, release the trigger and lock the gun in the "OFF" position. Securely connect the nozzle assy. (See "Nozzle Connection" pg. 11)

START-UP:

1. Refer to the "Safety Precautions" pgs. 4-7 before starting the unit.
2. Locate the Safety Decals on your unit and heed their warnings.
3. With the gun locked in the "OFF" position, point the trigger gun away from yourself or anyone else. Ensure water supply is turned completely on.
4. Disengage the safety lock-off on the gun and squeeze the trigger. Low pressure water will begin flowing from the nozzle.
5. Before starting the unit, brace yourself as the gun will kick-back from the high pressure created by the pump once the unit has started.
6. Move the On/Off Switch to the "ON" position. This switch includes a circuit breaker for protection of the motor. In case of excess load, the circuit breaker will automatically move the switch to the "OFF" position. To restart, move the On/Off Switch to the "ON" position again.
7. Once the unit is turned on, perform the following procedures with the gun open:
 - a. Inspect for system water leaks and oil leaks. If an oil leak is found, TURN UNIT OFF IMMEDIATELY! Be sure that all damaged parts are replaced and that the mechanical problems are corrected prior to operation of the unit. If you require service, contact Mi-T-M Customer Service.
 - b. Inspect high pressure hose for kinking cuts and leaks. If a cut or leak is found, DO NOT TOUCH HOSE AT CUT OR LEAK!!! TURN UNIT OFF IMMEDIATELY! Replace hose before re-starting the unit. See "Miscellaneous Safety Precautions #6, pg. 6. Be sure that all damaged parts are replaced and that the mechanical problems are corrected prior to operation of the unit. If you require service, contact Mi-T-M Service.
 - c. Inspect electrical cord for cuts. If a cut is found, DO NOT TOUCH OR USE ELECTRICAL CORD! Replace cord before starting the unit.
8. Trigger the gun several times and try adjusting the spray pattern. **Be certain** to LOCK the trigger gun in the "OFF" position whenever moving the adjustable nozzle. NEVER look directly into the nozzle! High pressure water creates a risk of severe injury!
9. Do not allow unit to operate in bypass mode (with trigger closed) for more than three minutes without triggering the gun. Failure to follow this simple rule can cause premature failure of pump packing seals, resulting in costly pump repair.
10. Because your pressure washer delivers a high pressure spray and a variety of spray patterns, there are many cleaning jobs that can be done without the use of detergents. If a cleaning agent is required, see "Cleaning With Detergents" pg. 15 for the correct procedures.



WARNING

RISK OF INJECTION CAUSING SEVERE INJURY!

- KEEP CLEAR OF NOZZLE! NEVER PLACE HAND OR FINGERS IN FRONT OF NOZZLE!
- DO NOT DIRECT DISCHARGE STREAM AT PEOPLE OR PETS!
- BE CERTAIN THE ADJUSTABLE NOZZLE ASSY. IS SECURELY CONNECTED TO THE WAND TO PREVENT AN ACCIDENTAL DISCHARGE!



CAUTION

RISK OF DAMAGE.

DONOT ALLOW SPRAY PATTERN TO REMAIN ON A FIXED AREA FOR AN EXTENDED PERIOD OF TIME. POSSIBLE DAMAGE MAY OCCUR TO THE AREA.

OPERATING INSTRUCTIONS

CLEANING WITH DETERGENTS:

1. Refer to "Detergent Cleaning Precautions" pg. 6 before working with detergents. Be certain to wear protective safety attire as stated on pg. 10.
2. Prepare detergent solution according to label directions. Never pump acids, alkaline, abrasive fluids or solvents through the unit.
3. Connect the detergent hose to the unit as shown on page 8.
4. Immerse the strainer into the detergent solution to allow detergent to siphon.
5. With the trigger gun locked in the "OFF" position, push the nozzle cover at the end of the wand away from the trigger gun.
6. To apply solution, unlock the trigger gun and squeeze the trigger. In a few moments a detergent/water mixture will exit the low pressure nozzle. Start spraying the lower portion of the surface being cleaned and move up, using long overlapping strokes. Applying from the bottom up helps avoid streaking. Allow to soak briefly. (Avoid working on hot surfaces or in direct sunlight to minimize the chances of the detergent drying, which may result in damaging surfaces.) Be certain to rinse a small section at a time.
7. To rinse; lock the trigger gun in the "OFF" position, pull the nozzle cover at the end of the wand toward the gun. Unlock the trigger gun and spray. It will take about 30 seconds to purge all detergent from the line. For best rinsing results, start at the top and work down.
8. Siphon a gallon of water through the low pressure detergent injection system after each use. This prevents the possibility of corrosion or detergent residue causing mechanical problems during the next use.

LOW PRESSURE/DETERGENT

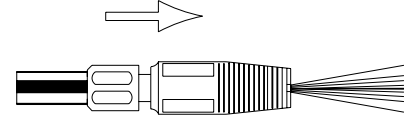

SHUT-DOWN:

1. Move the On/Off switch to the "OFF" position to turn unit off.
2. Turn the water supply "OFF".
3. Pointing the gun in a safe direction, trigger gun momentarily to relieve any trapped pressure.
4. Once pressure is relieved, disconnect the nozzle assembly.
5. Disconnect the unit from the power source.
6. Disconnect and drain gun, wand and hoses.
7. Wipe unit clean and store with gun, wand and hoses in a safe area.

STORAGE & MAINTENANCE

SPECIFIC MAINTENANCE:

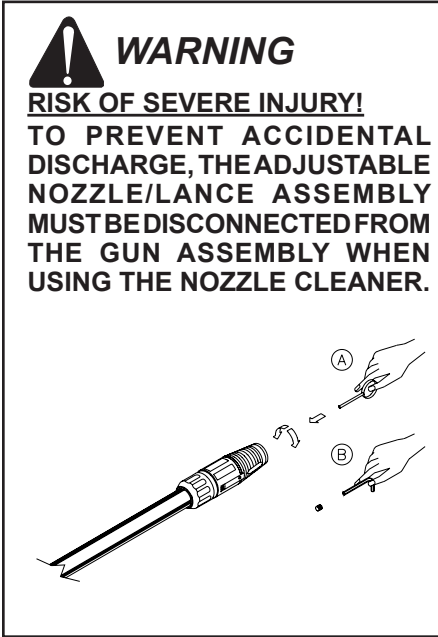

PUMP: The pump oil must be changed after the first 25 hours of operation. Once the initial oil change has been completed, it is recommended the oil be changed every 3 months or 250 hour intervals. If oil appears dirty or milky, changes may be required at a greater frequency. Use Mi-T-M pump oil #AW-4085-0016 and fill only to the center of the oil sight glass. **DO NOT OVERFILL!**

NOZZLES: Nozzle **orifices** should be kept clean and free of obstructions. If the nozzle becomes clogged, the pump pressure will increase. Therefore, should the nozzle become clogged, the nozzle orifice must be cleaned immediately. Follow the procedure listed below to clean nozzle orifice: (See **WARNING**, left.)

1. Disconnect the wand from the gun.
2. Insert the nozzle cleaner (supplied with unit) into the nozzle and rotate.
3. Flush the nozzle with water.
4. Reconnect the wand and gun assembly.
5. Turn the unit "ON". Point the gun in a safe direction and trigger the gun to begin spraying. Adjust spray pattern to 0°. If spray pattern is still distorted, repeat steps 1-4. If you are unable to thoroughly clean the nozzle using this procedure, then the nozzle must be replaced.

To Remove or Replace Adjustable Nozzle:

1. Insert a 2.0 mm allen wrench (supplied with the unit) into the nozzle.
2. Rotate the wrench counterclockwise to remove the nozzle.
3. Inspect the nozzle and clean or replace before re-inserting.

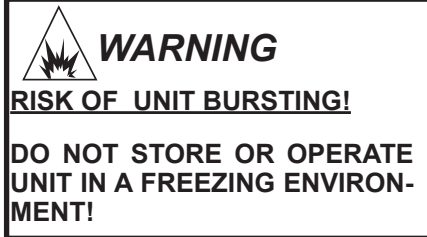

WINTERIZING:

For storage and transportation purposes in subfreezing ambient temperatures, it will be necessary to winterize this unit. This unit must be protected to the lowest incurred temperature for the following reasons:

1. If any part of the pumping system becomes frozen; excessive pressure may build up in the unit which could cause the unit to burst resulting in possible serious injury to the operator or bystanders.
2. The pumping system in this unit may be permanently damaged if frozen. **FREEZE DAMAGE IS NOT COVERED BY WARRANTY.**

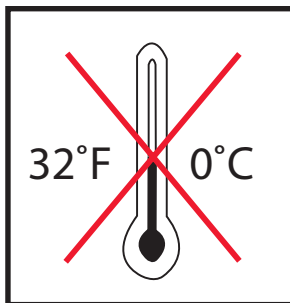

If you must store your unit in an area where the temperature may fall below 32°F, you can protect your unit by following the procedure outlined below.

1. Gather the following items:
 - a. Two 5 gallon containers.
 - b. One gallon of antifreeze. (Mi-T-M recommends an environmentally safe antifreeze.)
 - c. Water supply.
 - d. Three foot hose, 1/2-3/4 I.D. with a 3/4 inch male garden hose fitting.
2. Procedure:
 - a. To start winterizing, unit must be run and primed according to the "Start-up Procedures" listed on page 14.
 - b. After running and priming, shut off the unit and water supply.
 - c. Relieve system pressure by pointing the trigger gun in a safe direction and squeezing the trigger until water flow ceases to exit the nozzle.
 - d. Lock the trigger gun in an OFF position and remove the nozzle.
 - e. Remove the water supply hose from the unit and attach the 3 foot hose securely to the inlet connection.
 - f. Shut off the detergent injector if applicable.
 - g. Fill one 5 gallon bucket with water.

CONTINUED

Mi-T-M CD-1002/1502-0MUH/UC Operator's Manual

STORAGE & MAINTENANCE

WINTERIZING, CONT'D:

- h. Holding the 3 foot hose in an upright position, completely fill the hose with water. Then plug the hose outlet with your thumb or finger. Place the plugged end into the 5 gallon bucket of water.
- i. Turn the unit on. Trigger the gun several times until all the air is worked out of the system (unit is primed).

NOTE: *Proper winterizing is based on the recommended manufacturer's instructions listed on the "Protection Chart" shown on the back label of most antifreeze containers.*

- j. With the trigger gun held open, siphon enough water out of the 5 gallon bucket until there is just enough water left to mix with the antifreeze.
 - k. Point the wand into the empty container and start the unit.
 - l. Trigger the gun until the antifreeze begins to exit the wand. Release the trigger for 3 seconds, then trigger the gun for 3 seconds. Continue cycling the gun several times until all the antifreeze mixture is siphoned from the container.
 - m. Detach the 3 foot hose from the unit and drain any excess antifreeze back into the 5 gallon container.
 - n. Disconnect the hose/gun/wand assembly from the unit and drain any excess antifreeze back into the 5 gallon container.
 - o. Store the hose, gun and wand with the unit in a safe area.
 - p. Store antifreeze solution for next use or dispose of according to state EPA laws.
3. Optional Procedure:
- a. Shut the unit off.
 - b. Relieve system pressure by pointing the trigger gun in a safe direction and squeezing the trigger until water flow ceases to exit the nozzle.
 - c. Disconnect and drain the hose, gun and wand.
 - d. Start the unit and allow it to run until all the water exits the unit. Once the water has stopped flowing from the unit, turn off.

NOTE: *When using this procedure, caution should be used as ice chips can form from drops of water which could cause the unit to burst if starting before completely thawed.*

STARTING UNIT AFTER EXTENDED STORAGE:

1. BE CERTAIN the unit is NOT plugged into the power source.
2. Prior to restarting the unit, thaw out any possible ice from the wand, gun, hose and unit.
3. After following all "PREPARATION" instructions, start the unit momentarily and immediately turn "OFF" to ensure all parts are lubricated before operation.

TROUBLESHOOTING

SYMPTOM	PROBABLE CAUSE	REMEDY
Pump motor will not start, or stops while operating.	GFCI tripped.	Turn unit "OFF". Test GFCI by pressing reset button.
	Tripped circuit breaker or fuse blown in circuit fuse box.	Disconnect all other plugs on the circuit being used and reset circuit breaker OR check and replace fuse.
	Loose or disconnected plug.	Reconnect plug.
	Tripped circuit breaker in unit.	Allow to cool and restart unit.
	Unit is frozen.	Allow to thaw. If any part of the unit becomes frozen; excessive pressure may build up in the unit which could cause the unit to burst resulting in possible serious injury to the operator or bystanders.
Circuit breaker trips or fuse blows in the fuse box.	Circuit overload.	Check that the circuit is rated correctly. 15 Amp for 1000 PSI, 20 Amps for 1500 PSI. Disconnect all plugs on the circuit. When connecting to a circuit protected by fuses, use time delay fuses only.
	Extension cord is too long or wire is too small.	Use correct electrical requirements as listed on pg. 4.
	Too much pressure.	Use Adjusting Knob on Unloader to reduce pressure.
GFCI trips.	Incorrect voltage.	Ensure electrical supply is 120 V/15 A/60 Hz for 1000 PSI 120 V/20 A/60 Hz for 1500 PSI
	Electrical short to ground.	Contact Customer Service
Motor runs but there is no discharge at nozzle when trigger mechanism is squeezed.	Inadequate water supply.	Ensure hose is 3/4" diameter and incoming water supply is turned on.
	Kink in water inlet hose.	Remove kink.
	Kink in high pressure discharge hose.	Replace hose.
Low or fluctuating pressure.	Water inlet screen obstructed.	Remove screen, clean or replace.
	Pump sucking air. (Prime lost)	Tighten all water intake connections. Eliminate leaks in intake line.
	Not in high pressure mode.	Pull the nozzle cover toward the gun to engage in high pressure mode.
	Obstructed or worn orifice.	Remove and clean, or replace.
	Bypass valve not operating correctly.	Repair or replace.

TROUBLESHOOTING

SYMPTOM	PROBABLE CAUSE	REMEDY
Oil appears milky or foamy.	Water in oil.	Change pump oil. Fill to proper level.
Oil leaking from unit.	DO NOT USE!!!!	Contact Customer Service.
Detergent will not siphon into Low Pressure Detergent mode.	Detergent strainer is not completely	Check; submerge if necessary. submerged in detergent solution
	Detergent strainer is obstructed.	Inspect, clean or replace.
	Detergent hose is obstructed, cut or kinked.	Inspect, clean or replace.
	Not in Low Pressure mode.	Push nozzle cover away from the gun.
	Nozzle assembly is plugged.	Clean or replace.
	Too many high pressure hose extensions attached to the water outlet.	Use one extension maximum.
	Ball & Spring in Venturi stuck.	Remove, clean or replace.
Water flows back into detergent container.	Ball & Spring in Venturi reversed, missing or corroded.	Remove, clean or replace.
Water flows from the nozzle when the trigger gun is in the "OFF" position.	Gun is malfunctioning.	Repair or replace.

ACCESSORIES

15-0006:	3/4" Supply Hose
50-0085:	Extension Wand 18"
50-0086:	Angled Extension Wand 33.5"
50-0087:	Rotating Nozzle .035 mm
50-0090:	Wet Sandblaster
50-0091:	Foaming Wand
50-0092:	Hand Brush
50-0093:	Rotating Brush
50-0094:	Floor/Wall Brush
851-0007:	Extension Hose - 50'
AW-7005-01WK:	Wheel Kit
AW-7900-0300:	Hose Reel



STATEMENT OF WARRANTY

Mi-T-M warrants all parts, (except those referred to below), of your new pressure washer to be free from defects in materials and workmanship during the following periods:

For Lifetime against freezing and cracking:
Pump Manifold

For Seven (7) Years from the date of original purchase:
High Pressure Pump

For Two (2) Years from the date of original purchase:
Cart Assembly Plumbing

For One (1) Year from the date of original purchase:
GFCI Selector Switch

For Ninety (90) days from the date of original purchase:
Trigger Gun/Wand High Pressure Hose
Unloader Valve Strainer/Filter

Defective parts not subject to normal wear and tear will be repaired or replaced at our option during the warranty period. In any event, reimbursement is limited to the purchase price paid.

EXCLUSIONS

1. The Motor is covered under separate warranty by its respective manufacturer and is subject to the terms set forth therein.
2. Normal wear parts:
Pump Packings Spray Nozzles
Pump Valves Detergent Valves
Quick Couplings/Screw Connect O-rings
3. This warranty does not cover parts damaged due to normal wear, misapplication, misuse, operation at other than recommended speeds, pressures or temperature. Parts damaged or worn because of the use of caustic liquids or by operation in abrasive or corrosive environments or under conditions causing pump cavitation are not warranted. Failure to follow recommended operating and maintenance procedures also voids warranty.
4. The use of other than Genuine Mi-T-M Repair Parts will void warranty. Parts returned, prepaid to our factory or to an Authorized Service Center will be inspected and replaced free of charge if found to be defective and subject to warranty. There are no warranties which extend beyond the description of the face hereof. Under no circumstances shall Mi-T-M bear any responsibility for loss of use of the unit, loss of time or rental, inconvenience, commercial loss or consequential damages.

For Service or Warranty Consideration, contact Customer Service.
563-556-7484 / 800-228-6172 / Fax 563-556-1235
Monday - Friday 8:00 a.m. - 5:00 p.m. CST